

TYLER COUNTY COMMISSIONER'S COURT
 SPECIAL MEETING
 APRIL 15, 1983

VOL 008 PAGE 30

A Special Meeting of the Commissioner's Court met on Friday, April 15, 1983 at 10:00 A. M. All members being present. The meeting was opened with prayer by County Judge Allen Sturrock.

A motion was made by Commissioner Riley and Seconded by Commissioner Lowe to set up meetings for Monday, April 18, 1983, with Insurance Agents for Prudential Insurance Co. and American Teachers Insurance Co. Also, set for Friday, April 22, 1983, meetings are to be held with the American National Insurance Co. and Blue Cross-Blue Shield Agents to discuss the different plans accepted for the Tyler County Employees' Hospitalization Insurance. Bids accepted for consideration are listed as follows:

1. The Prudential Insurance Company of America.
2. American Teachers Life Insurance Company.
3. American National Insurance Company
4. Blue Cross-Blue Shield of Texas.

All voted yes and none no.

RECESSED FOR FIVE MENUTES.

IN SESSION

A motion was made by Commissioner Riley and seconded by Commissioner Odom to amend the Budget for the District Attorney's Office, as submitted by Ann Nichol, County Auditor. All voted yes and none no. See attached.

A motion was made by Commissioner Mahan and seconded by Commissioner Odom to approve a request by Barbara Tolbert to attend the annual Spring Conference-Seminar in McAllen, Texas, for Tax Assessors-Collectors. Approval was also granted for one Deputy from the Tax Office to attend the meeting with Tax Assessor-Collector Tolbert. All voted yes and none no.

A motion was made by Commissioner Mahan and seconded by Commissioner Odom to approve paying of bills, as submitted by Ann Nichol, County Auditor. All voted yes and none no. See attached.

A motion was made by Commissioner Lowe and seconded by Commissioner Odom to approve the bid from Triangle Equipment, Inc. for a Model 370 High Pressure Washer, to be used by Pct. II and Pct. IV. All voted yes and none no. See Attached. Bids submitted are listed as follows:

- | | |
|---|-----------|
| 1. Triangle Equipment, Inc.----- | \$1964.00 |
| 2. Triangle Equipment, Inc. (Bid not Acceptable-Specs Incorrect)- | 1755.00 |
| 3. Fourth St. Auto Parts (Bid not acceptable-Specs Incorrect)---- | 1459.15 |
| 4. Delco Cleaning Systems (Bid not acceptable-Specs Incorrect)--- | 1475.50 |
| 5. Davidson Const. Materials (Bid not acceptable-Specs Incorrect) | 2295.00 |

A motion was made by Commissioner Riley and seconded by Commissioner Lowe to table approval of the County Treasurer's monthly report, as submitted by County Treasurer Austin Fuller, until Monday, April 18, 1983, pending Corrections. All voted yes and none no.

A motion was made by Commissioner Riley and seconded by Commissioner Lowe to approve the bid from Mann Furniture Co. for a Whirlpool Air Conditioner for the Probation Department. All voted yes and none no. See Attached. Bids submitted are listed as follows:

- | | |
|-------------------------------|----------|
| 1. Mann Furniture Co.----- | \$429.00 |
| 2. McClure Furniture Co.----- | 499.95 |
| 3. The Furniture Center----- | 489.00 |
| 4. Dill's Appliance----- | 604.00 |

There being no further business, the meeting adjourned.

SIGNED: Allen Sturrock Allen Sturrock, County Judge
Maxie Riley Maxie Riley, Comm. Pct. #1
H. K. Lowe H. K. Lowe, Comm. Pct. #2
Jerry Mahan Jerry Mahan, Comm. Pct. #3
Berton A. Odom Berton A. Odom, Comm. Pct. #4
 ATTEST Grace Bostick Grace Bostick, County Clerk

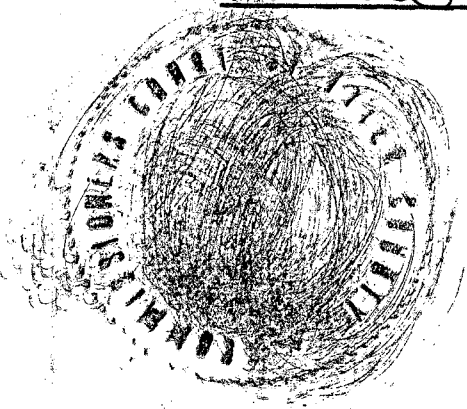

6

Nist. Attorney

INTER-OFFICE MEMO

Date 4-5-83

RE: BUDGET OVER-RUN

VOL 008 PAGE 32

There is a budget overage in the following line items:

<u>Office Supplies</u>	\$ <u>36.34</u>
<u>Telephone</u>	<u>71.74</u>
_____	_____
_____	_____

Will be used up this month.

Please come by the office within the next five days and amend your budget.

Thanks,
Ann Nichol
Ann Nichol
County Auditor

DO NOT WRITE BELOW - AUDITORS USE ONLY

Amendment:

Line Item:

From

To

Increase/
(Decrease)

Line Item:	From	To	Increase/ (Decrease)
_____	_____	_____	_____
_____	_____	_____	_____
_____	_____	_____	_____
_____	_____	_____	_____
_____	_____	_____	_____
_____	_____	_____	_____
_____	_____	_____	_____
_____	_____	_____	_____

Date of Signature _____

Authorization Signature _____

CLAIM REGISTER AND MINUTES OF ACCOUNTS ALLOWED, General FUND TYLER COUNTY, TEXAS

VOL 008 PAGE 33

Claim Number	NAME OF CLAIMANT	NATURE OF CLAIM	Amount of Claim	Date Allowed	Paid by Check No.
Tax Office: 22109	Western Data Services	April Lease on Data Processor	\$379.00		
22122	Southwestern Bell	Telephone	125.58		
21225	Rogers Office Supply	Office Supplies	28.20		
				532.78	
County Clerk: 22048	Hart Graphics	Forms	10.95		
21225	Rogers Office Supply	Office Supplies	126.10		
22122	Southwestern Bell Telephone	Telephone	78.08		
22115	Xerox Corporation	Copy Machine Supplies	39.70		
				254.83	
Dist. Court: 22063	John E. Kinney	Ct. Apptd. Atty/Cynthia A. Holden	175.00		
22028	James H. Dillion	" " Paul Logan, Jr.	100.00		
22018	James A. Clark	" " Granville Dennis	150.00		
22122	Southwestern Bell Telephone	Telephone	45.55		
				470.55	
J.P. I: 22072	Mattingly Printing Service	Letterheads & Envelopes	78.00		
22122	Southwestern Bell Telephone	Telephone	97.77		
22079	Office Supply Center	Supplies	2.85		
21225	Rogers Office Supply	Office Supplies	51.25		
22110	Walraven	Forms	24.63		
22090	Story Wright	Supplies	6.72		
J.P. II: 22122	Southwestern Bell Telephone	Telephone	21.39		
				282.61	
J.P. III: 22016	Colmesneil Telephone Co.	Telephone	18.13		
				18.13	

APPROVED THIS ¹⁵ day of April, 1978
Allen [Signature]
 COUNTY JUDGE

CLAIMS CHECKED AND APPROVED
Ann [Signature]
 COUNTY AUDITOR

Claim Number	NAME OF CLAIMANT	NATURE OF CLAIM	Amount of Claim	Date Allowed	Paid by Check No.
Building Maint: 22088	Sullivans Hardware	Janitors Supplies	40.59 /		
22087	Shepherds Linen Supply	Janitors Uniforms/1 month	46.25 /		
22084	Streets Pest Control	Exterminating Courthouse	75.00 /		
22021	Consolidated Marketing	Rest Room Supplies	70.18 /		
22020	Crocker Plumbing & Water Wells	Restroom fixtures (2nd Floor)	226.50 /		
22019	City of Woodville	Courthouse Utilities	1334.04 /		
22082	Phillips Heating & Air Cond.	Repl Motor in Veterans A/C.	235.19 /		
				2007.75	
Ageing Office: 22106	Woodville Auto Parts	Repairs to Mini-Bus	44.53 /		
22049	Hensarling Mobil Oil	Wash & Grease to Mini-Bus & Oil	46.70 /		
22015	City of Woodville	Utilities/Ageing Office	134.25 /		
22121	Tyler County Road & Bridge I	Gas Reimb. for March	181.24		
22122	Southwestern Bell Telephone	Telephone	30.57		437.29
County Judge: 22051	Information Guide on Co. Govt.	Up-Date to Manual	45.00 /		
22110	Walraven	Forms	15.62 /		
22122	Southwestern Bell Telephone	Telephone	98.72		
21225	Rogers Office Supply	Office Supplies	13.75		173.69

VOL 008 PAGE 34

APPROVED THIS 15 day of April, 1983
 COUNTY JUDGE [Signature]

CLAIMS CHECKED AND APPROVED
[Signature]
 COUNTY AUDITOR 21

CLAIM REGISTER AND MINUTES OF ACCOUNTS ALLOWED, General FUND TYLER COUNTY, TEXAS

Claim Number	NAME OF CLAIMANT	NATURE OF CLAIM	Amount of Claim	Date Allowed	Paid by Check No.
22101	Tex. Dist. & Co. Atty Assoc.	Forms	187.49		
22010	Becker Printing Co.	Forms	84.16		
22122	Southwestern Bell Telephone	Telephone	162.93		
22079	Office Supply Center	Supplies	14.90	449.48	
22066	Lamar Conner Auto Repair	Repairs to 1980 Ford & Chev.	911.14		
22107	Woodville Auto Parts	Repairs to Vehicles	89.50		
22100	Tyco Feed	Weight Tickets	12.00		
22083	Racal-Milgo	Rental on Teletype	147.00		
22081	Pickett-House	Meals for out-of-co ^o Dogwood Day Officers	112.50		
22122	Southwestern Bell Telephone	Telephone	456.33		
21225	Rogers Office Supply	Office Supplies	111.70		
22069	S. Magnolia Drive Inn Gro.	Meals for Prisoners	22.97		
22027	Diamond Shamrock	Gas	16.66		
22017	Conoco, Inc.	Gas	125.44		
22031	Exxon	Gas	317.24		
22038	J.E. Gardner Oil	Gas	774.58		
22054	Jackson Petroleum Prod.	Gas	535.44		
22070	Mobil Oil	Gas	15.27		
22062	Kilgore College	Tuition/Apshire, Coward, Gardner	115.00		
22009	Bobs Prescription Shop	Photos & Film	42.78		
22052	Jarrots Pharmacy	Film	23.53		
22037	John O. Gilchrist	Physicals for Coward & Apshire	30.00		

Dist. Atty.

Sheriff:

VOL 008 PAGE 35

(Continued on Page 4)

APPROVED THIS ¹⁵ day of April, 1978
Deane Chambers
 COUNTY JUDGE

CLAIMS CHECKED AND APPROVED
Deane Chambers
 COUNTY AUDITOR

3

CLAIM REGISTER AND MINUTES OF ACCOUNTS ALLOWED, General FUND TYLER COUNTY, TEXAS

Claim Number	NAME OF CLAIMANT	NATURE OF CLAIM	Amount of Claim	Date Allowed	Paid by Check No.
22014	Collier Ins. Agency	Liability Ins on Lease Cars ^{1 month}	129.00 ✓		
22008	Big Thicket Communications	April Radio Maint. & Changing Radios	288.25 ✓		
22123	Wal-Mart	Film	126.75 ✓		
22124	Brookshires	Food for Prisoners	390.43 ✓		
22090	Story-Wright	Office Supplies	75.87 ✓		
21233	A-Z Discount Auto Parts	Parts	61.19		
					4430.57
21229	3M	Maintenance Agreement/Copy Mach.	1,925.00		
22025	Deep East Texas Development Assoc.	Annual Dues	145.00 ✓		
22099	Tyler County Booster	Bids on Sheriffs Car/Advertising	24.58 ✓		
22109	Woodsman Publishing Co.	Bids on Insurance/Advertising	27.30 ✓		
22068	Monroe Calculator	Service Contract ^{Tax Off & Auditor} on Calculators	681.00 ✓		
22086	Southwestern Bell Telephone	County Share of Probation Phone	61.53		
22026	Deep East Tex. Workers Comp.	Workers Comp - April	574.24		3438.65
22091	Stafford Lowdon Co.	Forms	107.70 ✓		
22115	Xerox Corporation	Equipment Lease	315.00 ✓		
22122	Southwestern Bell Telephone	Telephone	65.27		
21225	Rogers Office Supply	Telephone	17.20		
					505.17
22013	Clemmons Insurance Agency	Liability Insurance	525.00 ✓		
22116	Jim Mahan Plumbing	Parts for Water Line	12.69 ✓		
22122	Southwestern Bell Telephone	Telephone	14.83		
					552.52

Sheriff:
(Contd)

Misc. &
Non-Departmental:

District Clerk:

Airport:

VOL 008 PAGE 36

APPROVED THIS ¹⁵ ~~14~~ day of April, 1983
 COUNTY JUDGE [Signature]

CLAIMS CHECKED AND APPROVED
[Signature]
 COUNTY AUDITOR

CLAIM REGISTER AND MINUTES OF ACCOUNTS ALLOWED, General FUND TYLER COUNTY, TEXAS

Claim Number	NAME OF CLAIMANT	NATURE OF CLAIM	Amount of Claim	Date Allowed	Paid by Check No.
Treasurer:	22090	Story-Wright	Office Supplies	124.22	
	21225	Rogers Office Supply	Supplies	17.70	
	22122	Southwestern Bell Telephone	Telephone	89.86	231.78
Highway-Patrol	22079	Office Supply Center	Supplies	13.23	
	21225	Rogers Office Supply	Supplies/Credit on ret'd. mdse)	(3.00)	
	22122	Southwestern Bell Telephone	Telephone	123.01	
	22067	Lufkin Typewriter	Typewriter Ribbons	32.00	165.24
Extension:	21225	Rogers Office Supply	Supplies	18.73	
	22122	Southwestern Bell Telephone	Telephone	90.22	
	22050	Linda Harrison	Mileage to 4-H/Nacogdoches	79.13	188.08
Foster Child Care:	22065	Mr. & Mrs. Wayne Lee	Care for Mary & Thomas ^{Wendy Winn Lorenz,}	682.00	682.00
County Attorney:	21225	Rogers Office Supplies	Supplies	.75	
	22122	Southwestern Bell Telephone	Telephone	53.90	54.65
Veterans Service:	21225	Rogers Office Supplies	Supplies	8.00	
	22122	Southwestern Bell Telephone	Telephone	28.75	36.75
Auditor:	21225	Rogers Office Supplies	Supplies	5.75	
	22122	Southwestern Bell Telephone	Telephone	32.55	38.30

APPROVED THIS ¹⁵ 15 day of April, 1983
Allen [Signature]
 COUNTY JUDGE

CLAIMS CHECKED AND APPROVED
[Signature]
 COUNTY AUDITOR

VOL 008 PAGE 37

CLAIM REGISTER AND MINUTES OF ACCOUNTS ALLOWED, General FUND TYLER COUNTY, TEXAS

Claim Number	NAME OF CLAIMANT	NATURE OF CLAIM	Amount of Claim	Date Allowed	Paid by Check No.
Parks & Wildlife: 22122	Southwestern Bell	Telephone	21.24	2/24	
J.P. IV: 22122	"	"	38.25	3/25	
County Court: 22001	Steve Annis	State of Texas vs/ Cain: 2 Copies of Exhibits	488.00 /	1/28.00	
				16,017.71	

VOL 008 PAGE 38

APPROVED THIS 15 day of April, 1983
Allen [Signature]
 COUNTY JUDGE

CLAIMS CHECKED AND APPROVED
[Signature]
 COUNTY AUDITOR

CLAIM REGISTER AND MINUTES OF ACCOUNTS ALLOWED, Law Library FUND TYLER COUNTY, TEXAS

Claim Number	NAME OF CLAIMANT	NATURE OF CLAIM	Amount of Claim	Date Allowed	Paid by Check No.
22085	Southwestern Bell Telephone	Telephone	23.28		

VOL 008 PAGE 39

APPROVED THIS ¹⁵ 14 day of April, 1983
Allen Chambers
COUNTY JUDGE

CLAIMS CHECKED AND APPROVED
Gene Stahl
COUNTY AUDITOR 17

Claim Number	NAME OF CLAIMANT	NATURE OF CLAIM	Amount of Claim	Date Allowed	Paid by Check No.
22086	Southwestern Bell Telephone	Telephone	20.61		
22026	Deep East Texas Workers Comp.	Workers Comp. Premium-April	4.52		

VOL 008 PAGE 40

APPROVED THIS ¹⁵ day of April, 1983
Allen [Signature]
 COUNTY JUDGE

CLAIMS CHECKED AND APPROVED
[Signature]
 COUNTY AUDITOR 8

CLAIM REGISTER AND MINUTES OF ACCOUNTS ALLOWED, Adult Probation FUND TYLER COUNTY, TEXAS

Claim Number	NAME OF CLAIMANT	NATURE OF CLAIM	Amount of Claim	Date Allowed	Paid by Check No.
22026	Deep East Tex. Workers Comp.	Workers Comp - April	9.46		
22086	Southwestern Bell Telephone	Telephone	27.15		
21228	Rogers Office Supply	Office Supplies	62.80		
22089	Story-Wright	Office Supplies	6.91		
22053	Impact Printing & Advertising	Receipt Books	140.00		
22047	Hart-Graphics	Legal Forms	69.60		

VOL. 008 PAGE 41

APPROVED THIS ¹⁵ ~~14~~ day of April, 1983
COUNTY JUDGE Allen [Signature]

CLAIMS CHECKED AND APPROVED
[Signature]
COUNTY AUDITOR 9

CLAIM REGISTER AND MINUTES OF ACCOUNTS ALLOWED, Road & Bridge I FUND TYLER COUNTY, TEXAS

Claim Number	NAME OF CLAIMANT	NATURE OF CLAIM	Amount of Claim	Date Allowed	Paid by Check No.
22004	A-Z Discount Auto Parts, Inc.	Parts	\$ 12.35		
22118	Mustang Tractor	Grader Blades & Parts	288.12		
22120	Oil City Tractors, Inc.	Parts	89.25		
22111	Woodville Auto Parts, Inc.	Repairs & Parts	933.51		
22102	Truner's Radiator & Custom Exhaust	Radiator Repairs	15.00		
22103	The Torque Shop	Repairs to Machinery	1378.00		
22039	Greenwood Exxon	Tire Repairs	77.00		
22052	Etox, Inc.	Rent on Bottles	77.00		
22029	Davis Food Market	Gas	10.60		
22055	Jackson Petroleum, Inc.-Gulf	Fuel	1413.05		
22045	Holderman's Building Center	Hardware	13.15		
22033	Freeman's	Culverts	1616.10		
22119	Gulf States Utilities Co.	Utilities @ Co. Barn	37.11		
22093	Seneca Water Supply Corp.	Water @ Co. Barn	8.50		
22094	South Magnolia Drive In Groc.	Ice	15.82		
22026	Deep East Texas Wrokers Comp.	April Permium	259.26		
		TOTAL	6,243.82		

VOL 008 PAGE 42

APPROVED THIS ¹⁵~~14~~ day of April, 1978
 COUNTY JUDGE *Deane D. Hancock*

CLAIMS CHECKED AND APPROVED
Ann Nihil
 COUNTY AUDITOR 10

CLAIM REGISTER AND MINUTES OF ACCOUNTS ALLOWED Road & Bridge II FUND TYLER COUNTY, TEXAS

Claim Number	NAME OF CLAIMANT	NATURE OF CLAIM	Amount of Claim	Date Allowed	Paid by Check No.
22112	Woodville Auto Parts	Parts & Labor	\$ 480.31		
22040	George P. Bane, Inc.	Repairs to Machinery	494.43		
22051	H & O Exxon	Tire Repairs	75.00		
22042	Goodyear Service Center	Tires	1169.15		
22034	Freeman's	Culverts	37.50		
22041	Gulf Selding Supply Co.	Rent on Bottles	7.20		
22056	J.E. Gardner Oil Co.	Fuel	1144.50		
22023	Chester Water Supply Corp.	Water @ Co. Barn	9.00		
22026	Deep East Texas Wrokers Comp.	April Permium	236.64		
			TOTAL 3,653.73		

VOL 008 PAGE 43

APPROVED THIS 15 day of April, 1978
 COUNTY JUDGE *Allen Charack*

CLAIMS CHECKED AND APPROVED
 COUNTY AUDITOR *[Signature]*

CLAIM REGISTER AND MINUTES OF ACCOUNTS ALLOWED, Road & Bridge III FUND TYLER COUNTY, TEXAS

Claim Number	NAME OF CLAIMANT	NATURE OF CLAIM	Amount of Claim	Date Allowed	Paid by Check No.
22011	Barrett Mack Sales & Service	Parts	\$ 43.75		
22030	Durham Saw Co.	Parts	123.60		
22061	Jimmy's Auto Parts	Parts	389.46		
22075	Mustang Tractor	Parts-711.55, Interest on			
		Promissory Note-497.00	1208.55		
22105	The Torque Shop	Front End Ball Joint-81 Chev.	140.00		
22007	Allison Chevrolet, Inc.	Bolts	8.70		
22005	Angelina Chevrolte- Cadillac	Parts	36.13		
22114	Woodville Auto Parts	Repairs-79 Chev.	33.67		
22097	Simmons Garage	Repairs-78 Chev.	80.00		
22080	Owens Exxon	Tire Repair, Kersone, & Ice	86.00		
22012	Beaumont Frame & Front End	Repair & Align-81 Chev.	48.10		
22058	Jasper Cheosoting Co.	Lumber	158.14		
22059	John Walker	5 hp Air Compressor	975.00		
22075	Martin's True Value	Tools & Hardware	69.33		
22117	Goodyear Auto Service Center	Tires	531.79		
22036	Freeman's	Culverts	1447.77		
22077	Mircham's Hilltop Groc. & Gas	Ice	41.03		
22098	Sears	Caculator	83.11		
22060	J.E. Gardner Oil Co.	Fuel	3084.45		
22006	Airco Welding Supply	Oxy., Acetylene, & Flux	28.96		
22024	Colmesneil Telephone Co.	Telephone @ Co. Barn	45.76		
22026	Deep East Texas Wroker's Comp.	April Premium	433.20		

VOL 008 PAGE 44

APPROVED THIS 15 day of April, 197 83

COUNTY JUDGE *Allen [Signature]*

Total 9,096.50

CLAIMS CHECKED AND APPROVED

COUNTY AUDITOR *Ann [Signature]* 12

CLAIM REGISTER AND MINUTES OF ACCOUNTS ALLOWED, Road & Bridge IV FUND TYLER COUNTY, TEXAS

Claim Number	NAME OF CLAIMANT	NATURE OF CLAIM	Amount of Claim	Date Allowed	Paid by Check No.
22073	Mustang Tractor	Filters	\$ 91.23		
22064	Knapp Ford Sales, Inc.	Parts	14.48		
22092	Smith's Service Center	Align	20.00		
22096	Spurger Gulf stateion	Parts	36.90		
22113	Woodville Auto Parts	Parts & Labor	716.56		
22057	J.E. Gardner Oil Co.	Fuel	1518.78		
22043	Gulf Welding Supply Co.	Welding Supplies	14.40		
22035	Freeman's	Culverts	156.48		
22074	McInnis Hardware & Supplies	Ice & Supplies	16.90		
22104	Tyler Co. Water Supply Corp.	Water @ Co. Barn	26.00		
22095	Southwestern Bell Telephone	Telephone @ Co. Barn	33.66		
22026	Deep East Texas Wroker's Comp.	April Permium	434.02		
		Total	3,079.41		

VOL 008 PAGE 45

APPROVED THIS 15 day of April, 1983
Allen Oran
COUNTY JUDGE

CLAIMS CHECKED AND APPROVED
Alan Hill
COUNTY AUDITOR

13

CLAIM REGISTER AND MINUTES OF ACCOUNTS ALLOWED, Federal Revenue Sharing FUND TYLER COUNTY, TEXAS

Claim Number	NAME OF CLAIMANT	NATURE OF CLAIM	Amount of Claim	Date Allowed	Paid by Check No.
	<u>SOLID WASTE</u>				
1636-a	Woodville Auto Parts	Parts	\$ 8.92		
1635-a	J.E. Gardner Oil Co.	Gas	368.00		
1633-a	Deep East Texas Worker's Comp.	April Permium	104.65		
			<i>TOTAL</i> 481.57		

VOL 008 PAGE 46

APPROVED THIS 15 day of April, 1983
Allen [Signature]
 COUNTY JUDGE

CLAIMS CHECKED AND APPROVED
Ann [Signature]
 COUNTY AUDITOR

14

Bid Accepted

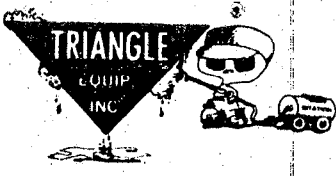

SALES • SERVICE • RENTALS
842-2525

PROPOSAL

1445 Lindbergh
Beaumont, Texas 77707

PROPOSAL NO. _____
DATE: 4-8-83

DISTRIBUTED IN YOUR AREA BY

Grace Bostick, County Clerk
Tyler County

FOR: Woodville, Texas 75979

VOL **008** PAGE **47**

AS DISTRIBUTORS FOR THE "TOTAL WASH SYSTEM" WE ARE PLEASED TO SUBMIT THE FOLLOWING PROPOSAL:

QTY	PRODUCT	DESCRIPTION	PRICE	TOTAL
1	Whitco	Model 370 High Pressure Washer	\$2455.00	\$2455.00
		3 GPM @ 700 PSI		
		110 Volts		
		A-30 Giant Triplex Pump		
		Open Gun		
		w/40 Ft. High Pressure Hose		
		Less 20% Discount		(491.00)
		Total		\$1964.00
			TOTAL PROPOSAL	\$1964.00

SPECIAL INSTRUCTIONS:

PRICES ARE FIRM FOR 30 DAYS.

TERMS: Net Receipt

F.O.B. Delivered

DELIVERY TIME: In Stock

[Signature]
SIGNED BY:

Whitco Inc.

Box 398, Hwy. 68 East
Siloam Springs, AR 72761
Telephone: (501) 524-6486

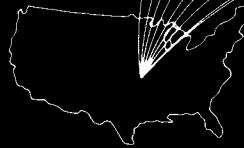

model 370 PEO

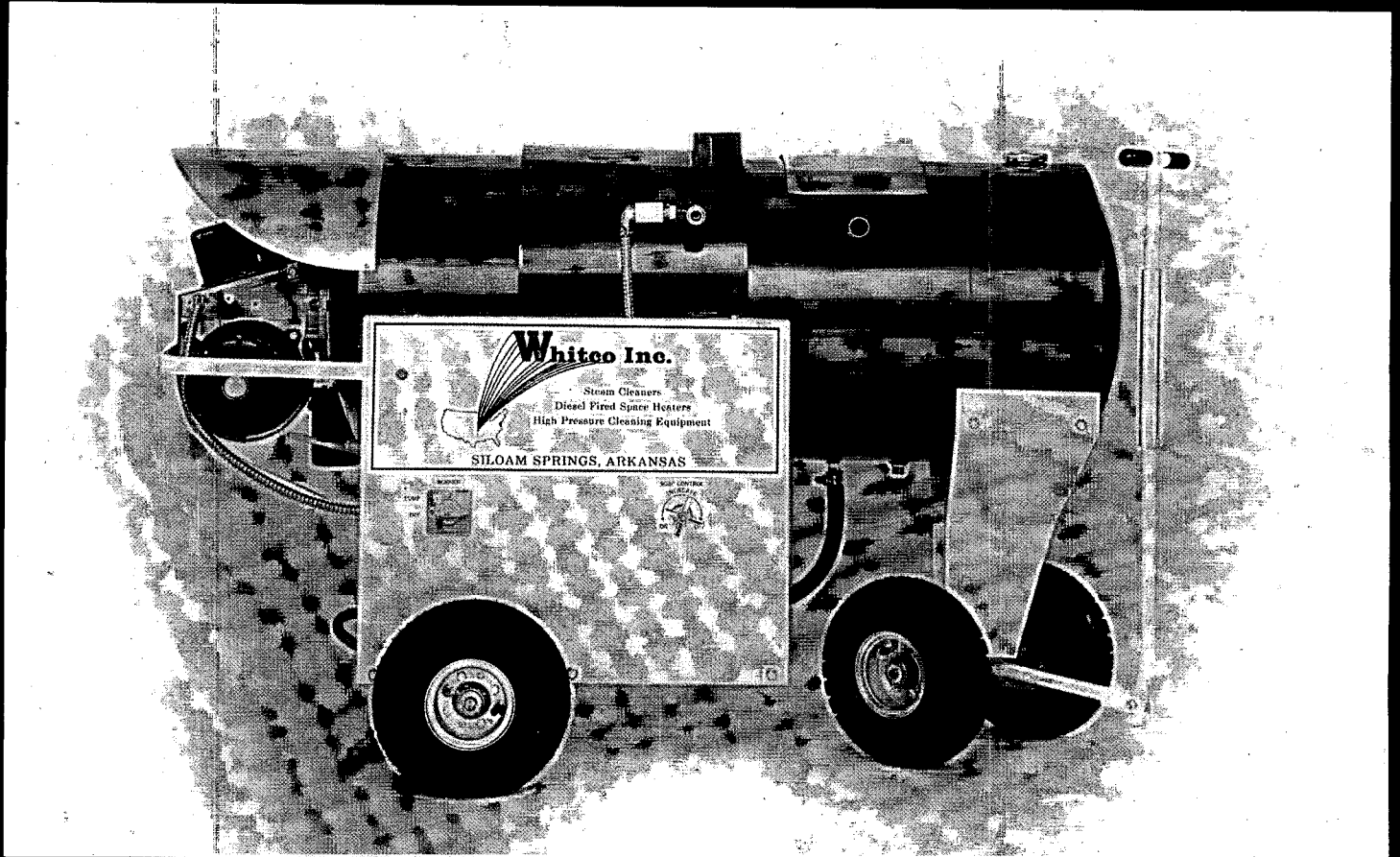

- Portable cleaning at its Best - Whitco offers a completely portable machine for all cleaning purposes in the 370 PEO.
- Thermostatically controlled heat, protected by a high limit switch and a pressure relief valve.

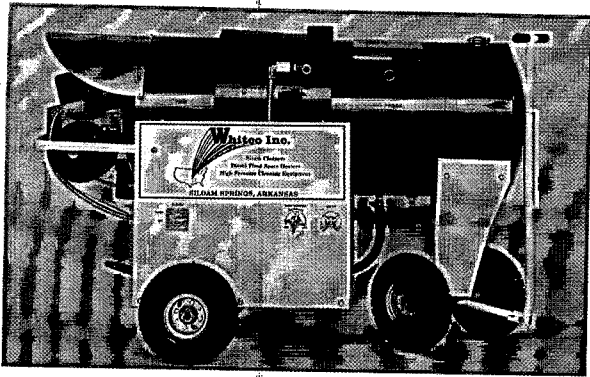

**model
3725 PEO**

OPERATING PRESSURE 110 GPH @ 250 PSI

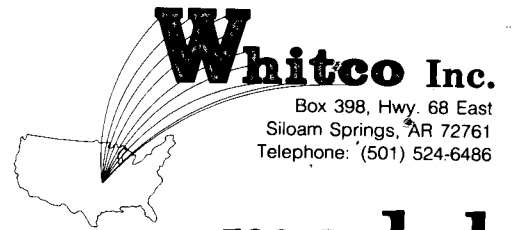

Box 398, Hwy. 68 East
Siloam Springs, AR 72761
Telephone: (501) 524-6486

**model
370 PEO**

OPERATING PRESSURE 3 G.P.M. @ 700 P.S.I. w/150° rise
BURNER Wayne Home (U.L. Listed) Automatic Light
FUEL Kerosene or diesel (Adjusted for diesel)
MOTOR 2 H.P.
BURNER MOTOR 1/5 H.P., 3450 RPM
WATER PUMP (Giant) A30K Belt Drive
COIL SIZE 7/8" O.D. x 135'
HIGH PRESSURE HOSE 3/8" x 40' 1 wire braid
GUN Open with expanded metal handle
FUEL CAPACITY 10 Gallon
FLOAT TANK CAPACITY 7 Gallon
DIMENSIONS H 36", L 57", W 27 1/2", W 385 lbs.

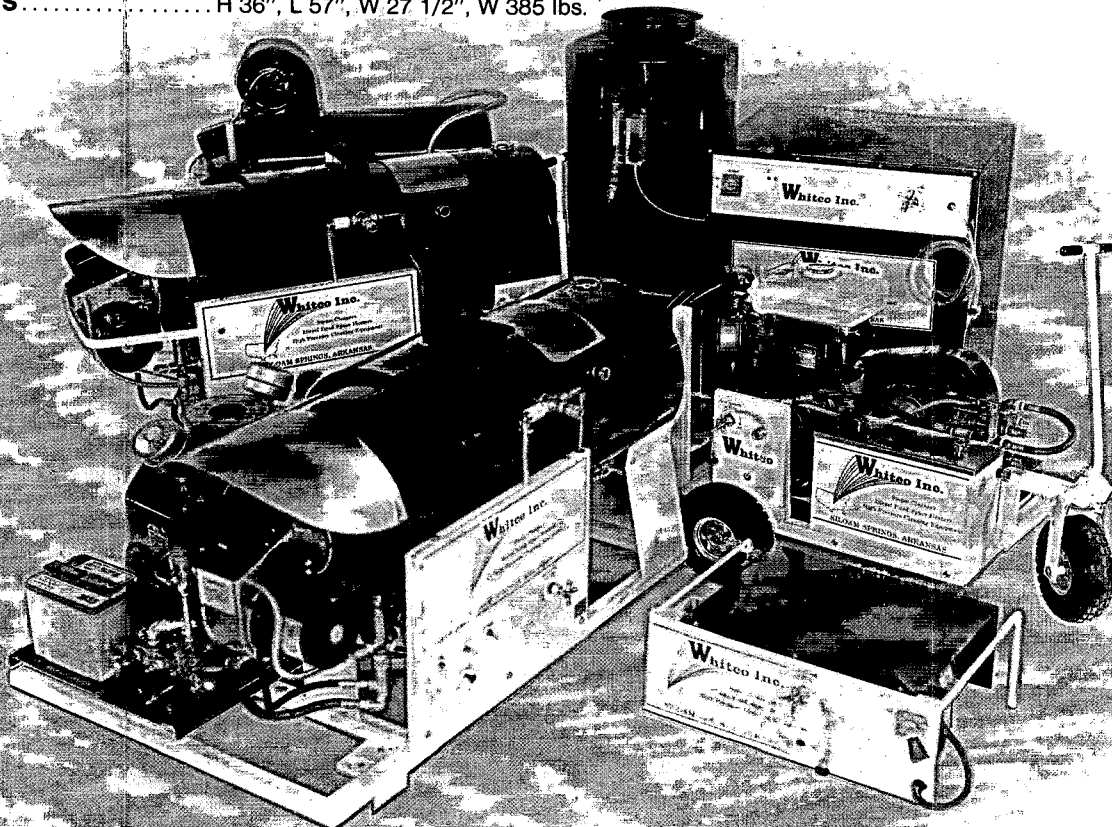
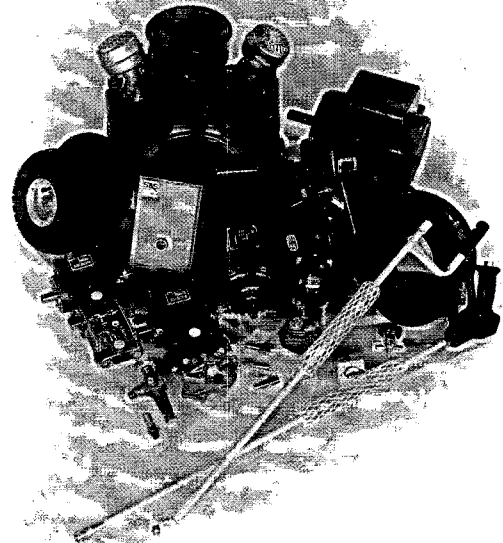

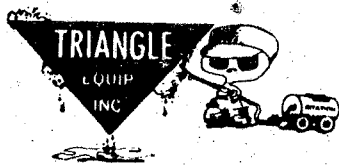

SALES • SERVICE • RENTALS
842-2525

PROPOSAL

1445 Lindbergh
Beaumont, Texas 77707

PROPOSAL NO. _____
DATE: 4-8-83

DISTRIBUTED IN YOUR AREA BY:

Grace Bostick, County Clerk
Tyler County

FOR: Woodville, Texas 75979

VOL **008** PAGE **48**

AS DISTRIBUTORS FOR THE "TOTAL WASH SYSTEM" WE ARE PLEASED TO SUBMIT THE FOLLOWING PROPOSAL:

QTY	PRODUCT	DESCRIPTION	PRICE	TOTAL
1	Ghibli	Model 50 High Pressure Hot Water Washer	\$1755.00	\$1755.00
		Galvanized Steel Cabinet		
		3 GPM @ 725 PSI		
		40. Ft. High Pressure Hose		
		Trigger Gun Control		
		Thermostat Control		
		Pressure Gauge		
		110 Volts		
		2 Piston Pump		
		1½ HP Electric Motor		
TOTAL PROPOSAL				\$1755.00

SPECIAL INSTRUCTIONS:

PRICES ARE FIRM FOR 30 DAYS.

TERMS: Net Receipt

F.O.B. Delivered

DELIVERY TIME: In Stock

[Signature]
SIGNED BY:

Ghibli

**METALLIC COVERED
HOT WATER PRESSURE WASHERS**

**50 BAR
725 PSI**

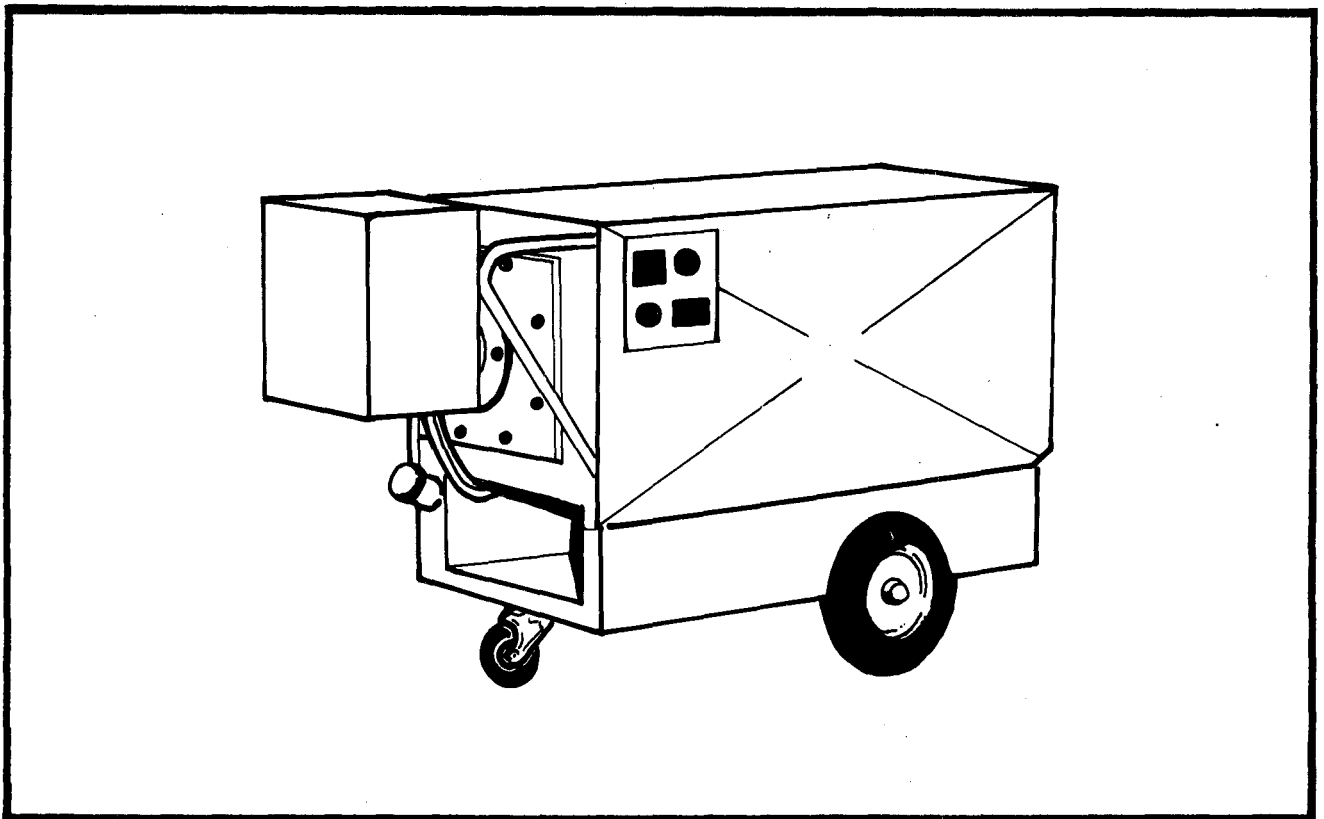

Ghibli North American

14 Germay Drive
Wilmington, Delaware 19804
(302) 654-5908

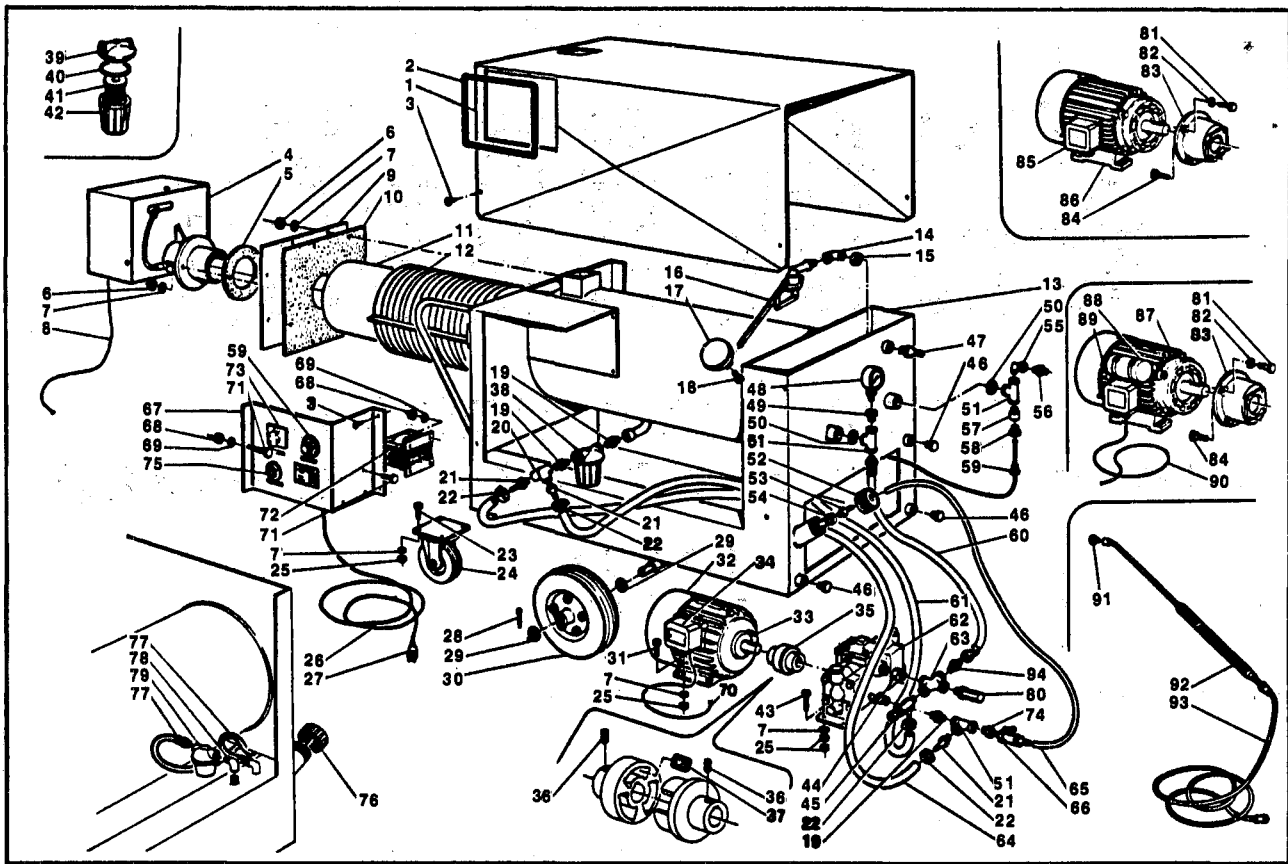

PARTS LIST

Item No.	Part No.	Qty.	Description	Denominacion
1	300271	1	Metal cover	Chapa
2	300272	1	Rubber trim	Perfil
3	-	6	Self-Tapping screw ϕ 4.75	Tornillo autorroscante ϕ 4.75
4	400500	1	Burner assembly	Quemador
5	400501	1	Asbestos packing	Guarnicion de amianto
6	-	10	Nut, 8MAx6-brace	Tuerca, 8MAx6-laton
7	-	22	Washer, ϕ 8	Arandela, ϕ 8
8	300326	1	Electric cable-Burner	Cable electrico-Quemador
9	300354	1	Plate	Placa
10	300353	1	Asbestos packing	Guarnicion de amianto
11	300377	1	Heating jacket	Camisa de calefaccion
12	300376	1	Coil	Serpentin de calefaccion
13	300275	1	Frame	Bastidor
14	300420	1	Connector 3/4"-elbow	Union de tubos en codo-3/4"
15	300396	1	Back nut	Controtuerca
16	300392	1	Cock, Float	Grifo de Flotador
17	300391	1	Ball, copper	Bola-cobre
18	-	1	Screw	Tornillo
19	300408	3	Nipple 1/2"	Racor 1/2"
20	300412	1	Three-way connector 1/2"	Union de tres vias 1/2"
21	300343	3	Connection hose	Union de tubo goma
22	-	4	Clamp 12/20	Abrazadera de sujecion tubo 12/20
23	-	4	Screw 8MAx16	Tornillo 8MAx16
24	300380	1	Wheel	Rueda
25	-	16	Nut 8MA	Tuerca 8MA
26	300283	1	Three-phase electric cable	Cable electrico trifasico
26	300295	1	Single-phase electric cable	Cable electrico monofasico
27	300330	1	Three-phase electrical plug	Echufe de corriente trifasico
27	300296	1	Single phase electrical plug	Echufe de corriente monofasico
28	300365	2	Cotter pin	Pasador
29	-	4	Washer ϕ 21	Arandela ϕ 21

Item No.	Part No.	Qty.	Description	Denominacion
30	300361	2	Wheel	Rueda
31	-	4	Screw 8MAx25	Tornillo 8MAx25
32	300321	1	Three-phase electric motor	Motor electrico trifasico
33	-	1	Key	Claveta
34	300293	1	Junction box	Caja de conexion
35	300319	1	Coupling assembly	Acoplamiento
36	-	2	Dowel 8MA	Clavija 8MA
37	300324	6	Rubber joint	Junta de goma
38	300273	1	Water filter	Filtro agua
39	300268	1	Strainer cap	Tapa de colador
40	300270	1	Seal ring	Anillo de junta
41	300289	1	Cartridge	Cartucho
42	300288	1	Filter box	Caja de filtro
43	-	4	Screw 8MAx55	Tornillo 8MAx56
44	300277	1	Connector-Reduction 1/4"-3/8"	Union de reduccion 1/4"-3/8"
45	300328	1	By-pass valve	Valvula auxiliar
46	300414	3	Plug 3/8"	Tapon 3/8"
47	300393	1	Connector hose 3/4"	Union de tubo goma 3/4"
48	300311	1	Pressure gauge	Manometro
49	300341	1	Connector-Reduction	Union de reduccion
50	300347	2	Washer	Arandela
51	300404	3	Tee 1/2"	Union de tubos en T-12"
52	300274	1	Cap	Tapon
53	300399	1	Connector hose 3/8"	Union de tubo goma 3/8"
54	300320	1	Detergent filter	Filtro detergente
55	300411	1	Connector 1/2" elbow	Union de tubos en codo 1/2"
56	300417	1	Nipple 1/2"	Racor 1/2"
57	300346	1	Spacer sleeve 1/2"	Manguito separador 1/2"
58	300345	1	Reduction thermostat	Reduccion termostato
59	300359	1	Thermostat	Termostato
60	300344	1	Flexible pipe	Tubo flexible
61	300276	1	Hose	Tubo de goma
62	300317	1	Water pump R5	Bomba agua R5
63	300278	1	Four-way connector 3/8"	Union de cuatro vias 3/8"
64	300280	1	Hose	Tubo de goma
65	300279	1	Hose	Tubo de goma
66	300400	1	Cock	Grifo
67	300287	1	Instrument panel-assembly	Tablero de instrumentos
67	300286	1	Panel	Tablero de instrumentos
68	-	5	Nut 5MA	Tuerca 5MA
69	-	5	Washer ϕ 6	Arandela ϕ 6
70	300281	1	Three-phase electric cable	Cable electrico trifasico
71	-	5	Screw 5MAx10	Tornillo 5MAx10
72	300360	1	Autotransformer	Autotransformador
73	300285	1	Three-phase switch	Interruptor trifasico
73	300284	1	Single-phase switch	Interruptor monofasico
74	300313	1	Connector-Reduction 1/2"-3/8"	Union de reduccion 1/2"-3/8"
75	300358	1	Switch, burner	Interruptor quemador
76	300282	1	Cap	Tapon
77	300384	2	Flexible pipe	Tubo flexible
78	300381	1	Connector, 3/8"-elbow	Union de tubos en codo-3/8"
79	300382	1	Gas oil filter	Filtro gasoil
80	300402	1	Safety valve	Valvula seguridad
81	-	4	Screw, 8MAx25	Tornillo 8MAx25
82	-	4	Washer, ϕ 8	Arandela ϕ 8
83	300303	1	Bell	Campana
84	-	4	Screw, 6MAx20	Tornillo 6MAx20
85	300294	1	Junction box	Caja de conexion
86	300304	1	Three-phase electric motor	Motor electrico trifasico
87	300297	1	Single-phase electric motor	Motor electrico monofasico
88	300291	1	Condenser	Condensador
89	300292	1	Junction box	Caja de conexion
90	300267	1	Single-phase electric cable	Cable electrico monofasico
91	300269	1	Jet	Baquilla dell'aspersor
92	300424	1	Nozzle WW25	Aspersor WW25
93	300421	1	Hose	Tubo de goma
94	300340	1	Nipple 3/8"-1/2"	Racor 3/8"-1/2"

SPECIFICATIONS

MODEL		Ghibli 50
Pump	Ceramic Coated Pistons; Oil Bath	2
Pressure max	(Bar) (Psi)	50 725
Capacity max	(lt/min.) (U.S.-GPM.)	11 2.8
Units of cleaning energy		121,800
Temperature max	(°C) (°F)	100 212
Electrical data		110/220V 60Hz 1½HP
Diesel tank capacity	(lt.) (U.S.gal)	10 2.6
Fuel consumption	(Kg/h) (U.S.gal/h)	4.9 1.7
Heating coil	(Ø)	½"
Detergent tank capacity	(lt.) (U.S.gal)	10 2.6
Detergent intake		2
Valves metering		1
High pressure rubber hose	(mm.) (FT)	12,000 40'
Height	(mm.) (in.)	750 29.5"
Length	(mm.) (in.)	1160 45.6"
Width	(mm.) (in.)	650 25.5"
Weight	(Kg) (LBS)	175 386

* AT MINIMUM CAPACITY

SUPERIOR ADVANTAGES OF GHIBLI MACHINES

- Robust steel frame.
- Heating coil 1/2" in diameter (3/8" for most competitive models) leading to longer life and less likelihood of break-downs.
- Thermic steel combustion chamber assuring the best possible combustion.
- Combustion pressurized and thus independent of atmospheric conditions.
- Boiler at two or three turns of flame for the most complete and efficient use of fuel.
- The boiler is immersed in the same water which passes then to the pump and heating coil. Thus is obtained the double advantages of cooling the boiler and preheating the water. This assures increased production, a reduction in the consumption of fuel and a much longer life for the heating coil.
- Exclusive Ghibli thermostat controlling heat of water with bulb directly immersed in water—eliminates variations in water temperatures and reheating delays.
- Exclusive burner system of Ghibli construction with continuous ventilation and sparking for a regular and secure flame.
- Fuel tank of large capacity.
- Extremely easy to service.
- Pump with ceramic coated steel pistons. Assures maximum reliability and minimum operating noise.
- Adaptable for hydro-sandblasting from 1450 P.S.I. to 2900 P.S.I.
- Acid shooting capacity present in all models.
- Two detergent intakes (some models).
- Wide selection of lances.
- Trailer mounted units including all components for completely autonomous operation are available.
- For cleaning internal tubing, piping, cylinders, cisterns, etc., a rotating head model is provided.
- Cold water cleaners up to 2900 P.S.I.
- Hydro-sandblasting up to 2900 P.S.I. with hot or cold water. Steel, sand suction tube available.
- Bypass for recirculation of water in the pump.
- Lance nozzles can be manipulated into desired positions.
- 12-month guarantee on boiler and heating coil.
- Convertible into steam.
- Marketed in 35 countries.
- Special machines and systems available.
- Special fiber glass covers available for most models.

STANDARD ACCESSORIES — One thermostat for adjusting working temperature; one overload cutout protecting the pump's electric motor; one burner switch; one diesel fuel burner with continuous duty exceptional power ignition transformer; one washing lance with insulated handle; 40 ft. high-pressure hose.

Fourth Street Auto Parts

675 S. 4th Street • Phone 838-0571

Beaumont, Texas 77701

VOL 008 PAGE 50

April 5, 1983

Grace Bostic
County Clerk
Tyler County
Woodville, Texas

Dear Mrs. Bostic

We have a model 200C super jenny steam cleaner in stock. We can sell it for \$1,459.15. It has the following specifications:

115 volts	115# pressure
20 amps	2.25 G/P/H water
portable with 25' hose	

We can furnish one from the factory warehouse, model 200C super jenny steam cleaner with the same specifications as above for \$1,759.00.

These prices are F.O.B Woodville, Tx, unless we receive an order for only one, then it is F.O.B Beaumont, Tx.

Thank you for the privilege of bidding.

Yours Truly,



Robert Cauble, Manager

RC/ah

FOURTH STREET AUTO PARTS
675 SOUTH FOURTH ST
BEAUMONT, TEXAS 77701



VOL 008 PAGE 51

NO. _____ TIME: 10:00 ^{AM}/_{PM}

APR 07 1983

GRACE BOSTICK, COUNTY CLERK
TYLER COUNTY, TEXAS

BY: *Grace Bostick*

Grace Bostick
County Clerk, Tyler County
Room 110
#100 County
Woodville, Tx 75979

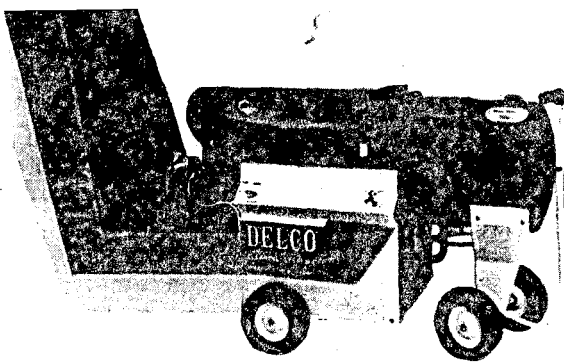

DELCO

CLEANING SYSTEMS

3701 Ellen Trout Drive, Sp 1, Lufkin, Texas 75901
P. O. Box 709 • 639-3478

April 5, 1983

VOL 008 PAGE 52

County Clerk Department
Courthouse 100
Woodville, Texas

Attention: Grace Bostick

Please consider this as our bid for two (2) Mach II hot hi-pressure washers.

Specifications are listed below:

DISCHARGE CAPACITY	2.4 GPM
OPERATING PRESSURE	1000 PSI
OPERATING TEMPERATURE	200°
FUEL	Kerosene, No. 1, No. 2 Diesel
PUMP	2 piston, ceramic plunger, oil bath
PUMP MOTOR	1½ HP, 115V, 60 HZ, 1 phase
HOSE	3/8" x 40' safety wire braid
GUN	open
CHEMICAL CONTROL	metered injector valve
APPROXIMATE SHIPPING WEIGHT	450 pounds
DIMENSIONS	28" W x 57" L x 36" H
CODE NO. 000858	oil fired, electric

Your cost (each)\$1475.50

If paid within 10 days, you may deduct 5% (73.68) making your cost \$1401.72.

If you have further questions, please do not hesitate to call.

Thank you,

Walter Gray
Walter Gray

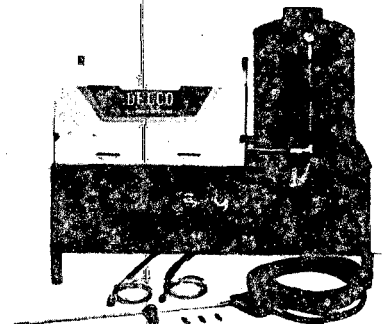

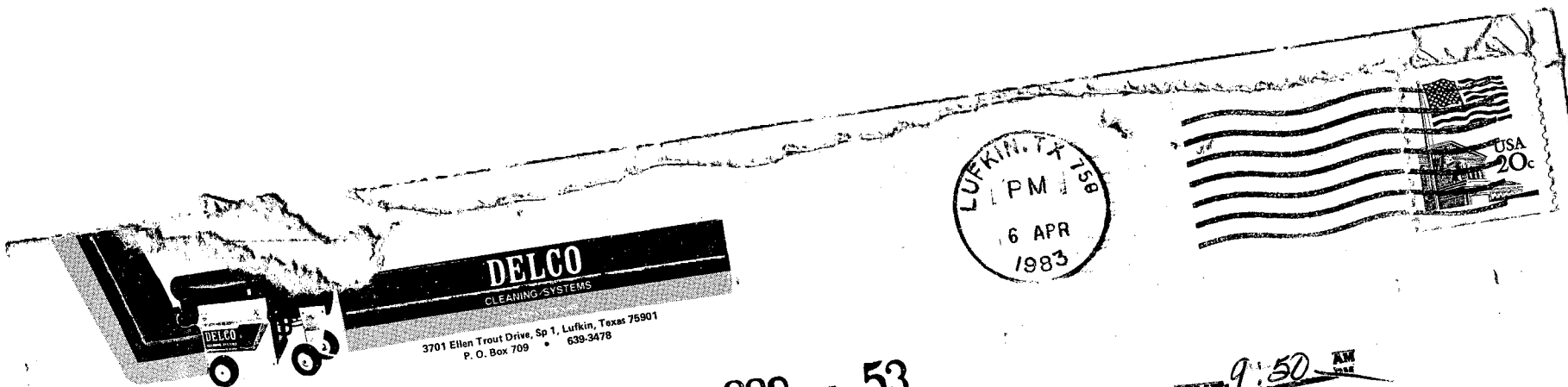

LUFKIN, TX 75801
PM
6 APR
1983

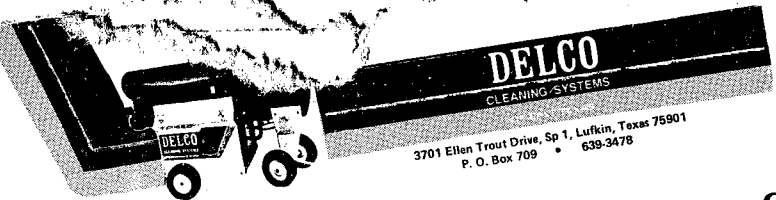
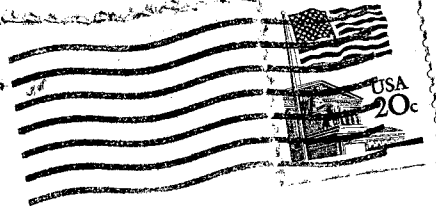

DELCO
CLEANING SYSTEMS
3701 Ellen Trout Drive, Sp 1, Lufkin, Texas 75901
P. O. Box 709 • 639-3478

VOL 008 PAGE 53

County Clerk Dept.
Court House 100
Woodville, Texas 75979

NO. _____ TIME: 9:50 AM

APR 07 1983
GRACE BOSTICK, COUNTY CLERK
TYLER COUNTY, TEXAS
BY: *Grace Bostick*

(BID)

(BID)

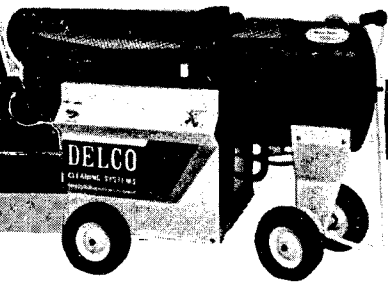

DELCO

CLEANING SYSTEMS

OF EAST TEXAS

3701 Ellen Trout Drive, Sp 1, Lufkin, Texas 75901
P. O. Box 709 • 639-3478

April 5, 1983

VOL 008 PAGE 54

County Clerk Department
Courthouse 100
Woodville, Texas

Attention: ~~Grace Bostick~~

Please consider this as our bid for two (2) Mach II hot hi-pressure washers.

Specifications are listed below:

DISCHARGE CAPACITY	2.4 GPM
OPERATING PRESSURE	1000 PSI
OPERATING TEMPERATURE	200°
FUEL	Kerosene, No. 1, No. 2 Diesel
PUMP	2 piston, ceramic plunger, oil bath
PUMP MOTOR	1½ HP, 115V, 60 HZ, 1 phase
HOSE	3/8" x 40' safety wire braid
GUN	open
CHEMICAL CONTROL	metered injector valve
APPROXIMATE SHIPPING WEIGHT	450 pounds
DIMENSIONS	28" W x 57" L x 36" H
CODE NO. 000858	oil fired, electric

Your cost (each) \$1475.50

If paid within 10 days, you may deduct 5% (73.68) making your cost \$1401.72.

If you have further questions, please do not hesitate to call.

Thank you,

Walter Gray
Walter Gray

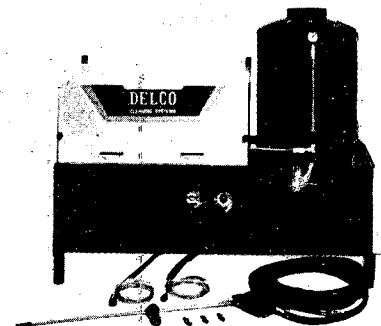

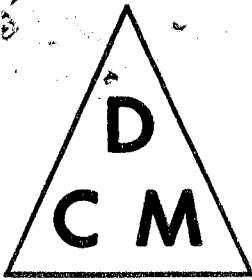

Davidson
CONSTRUCTION MATERIALS
Inc.

P. O. BOX 6267

BEAUMONT, TEXAS 77705

PHONE 722-4321

April 12, 1983

HOTSY 610E

Discharge capacity-----	3gpm or 180gph
Operating Pressure-----	750psi
Heat Rise-----	120° (will raise the temperature of the water going into the cleaner 120°. Example: if the water temp. is 50° going into the cleaner, it will be discharged at 170°.)
Pump Motor-----	1 1/2 HP: 115 Volts 60 cycle, 1 phase thermal overload protection; drip proof, dual capacitor.
Oil Fired Burner-----	Pressure atomizing; forced air automatic electric ignition UL approved.
Hose-----	40', 3/8" ID hose.
TOTAL PRICE-----	=\$2,295.00 each

Enclosed is a brochure which will explain in detail the equipment specifications.

OPTIONS:

Portability Kit-----	\$160.24 each
Trigger gun control-----	\$325.27 each

610E



The industry's most popular 3-GPM, 750-PSI, hot-water washer is now the industry's best mid-size cleaner value!

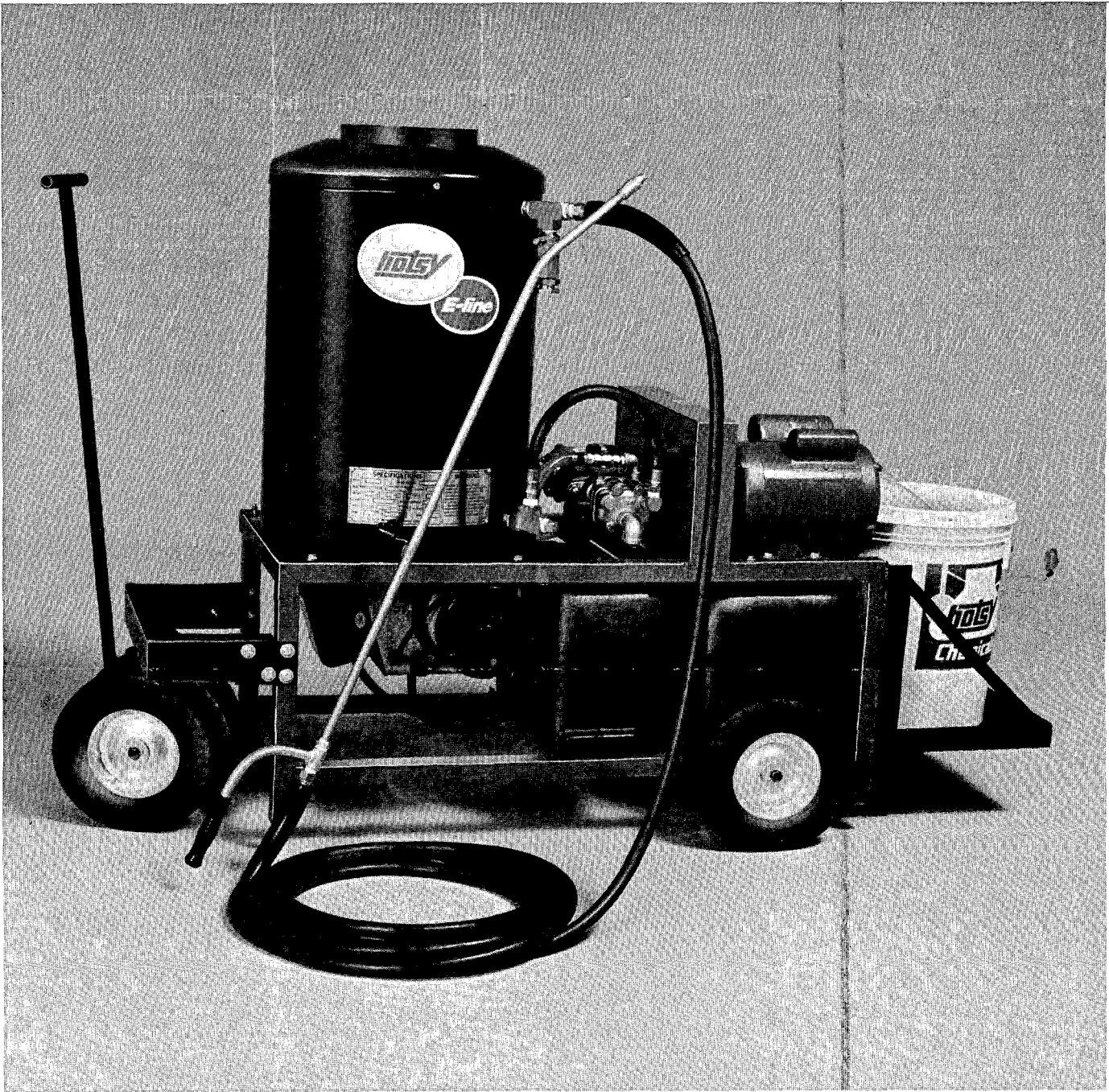

Our Hotsy E-line is designed to give you top performance at bottom dollar.

If you're looking for versatility from a mid-size, hot-water washer... that's simply designed, simple to operate and simple to maintain... with enough cleaning punch to sweep away the heaviest-layered grime and to blast away the hardest-packed dirt... that's priced so low that any business, of any size, can easily afford it... then you're looking for our Hotsy 610E!

Our Hotsy 610E has the same high-quality, high-performance components that have made Hotsys the leaders in the industrial cleaning industry: the same quality motors, our incomparable Hotsy Shark/300 triplex plunger pump and our efficient heating system.

What's more, all the sophisticated controls and accessories for which The Hotsy Corporation has become famous are available as options for our Hotsy 610E.

In short, the Hotsy 610E delivers top performance at bottom dollar.

The Hotsy Man nearest you wants to come to your place of business to show you what his Hotsy 610E can do with your cleaning problems. Let him show you how the Hotsy E-line saves you cleaning time... **and money.** Call him today!

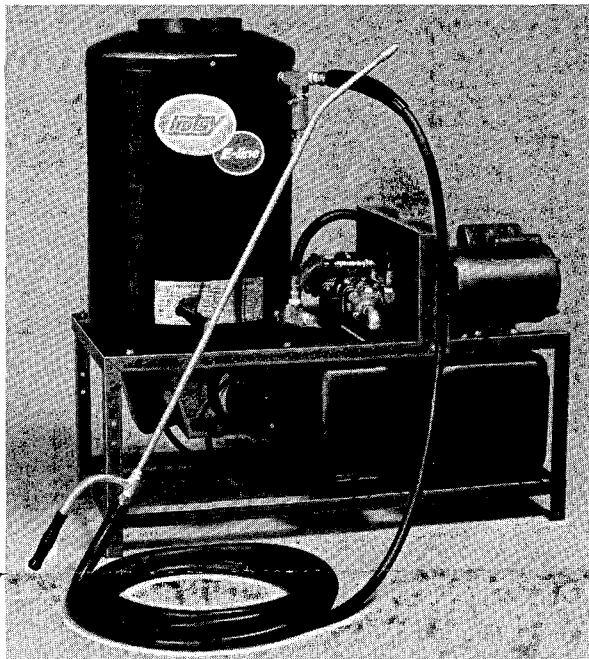

SPECIFICATIONS: 610E

Discharge Capacity	3 GPM; 180 GPH
Operating Pressure	750 PSI.
Heat Rise	120° F.
Water Pump	Hotsy Shark/300 triplex, with stainless steel plungers and internal U-cup seals; positive displacement; oil-bath crankcase.
Pump Motor	1-1/2 HP, 115 volt, 60 cycle, 1 phase; thermal overload protection; drip proof; dual capacitor.
Oil Fired Burner:	
Type	Pressure atomizing; forced air; automatic electric ignition; UL approved.
Burner Motor	1/5 HP, 3450 RPM, 115/60/1; thermal overload protection.
Burner Nozzle Size	1.64 GPH.
Input	230,000 BTU/Hr.
Fuel Type	#2 Diesel, Kerosene or #1 Home Heating Oil.
Fuel Tank	6 Gallons, removeable, non-contaminating, high-density polyethylene.
Gas Fired Burner:	
Type	Ring type with aspirating spuds; natural draft.
Controls	AGA approved.
Fuel Type	Natural or LP gas.
Heating Coil	5/8" OD; continuous length, seamless steel tubing, heavy-walled; 1000 PSI hydrostatic pressure tested; 22,000 PSI burst-pressure rated; vertically fired.
Stack Size	Oil fired: 8". Gas fired: 10". Gas-fired units require draft diverters.
Controls:	
Safety Relief Valve	Preset to release pressure for component protection.
Switches	Pump Motor: Manual start; heavy-duty toggle switch. Burner: Heavy-duty toggle switch.
Floater Valve	Automatic, non-contaminating.
Soap Valve	On/off ball valve. Interchangeable orifice metering system.
Temperature	Adjustable thermostat optional.
Floater Tank	Non-corrosive, non-contaminating, high-density polyethylene.
Gun	Open type; heavy duty. (Trigger-control Kit optional.)
Nozzle	One 15° stainless steel.
Hose	3/8" ID x 50 Ft. length. Extra lengths optional. Single-wire braid. 2250 PSI working pressure rated. Oil and chemical resistant.
Portability	Optional.
Materials	Heavy-gauge, angle-iron frame.
Finish	High-gloss, baked enamel.
Dimensions:	
Stationary	L-37"; W-16"; H-40".
With Portable Gear	L-48 1/2"; W-16"; H-40 1/4".
Net Weight:	Oil fired: 240 lbs.
Shipping Weight - Domestic (Export Container Optional)	Oil fired: 270 lbs.

THE HOTSY 610E SERIES: 3 GPM; 750 PSI; 115/60/1.

Model 610E	Oil fired, portability optional.
Model 611E	LP gas fired, portability optional.
Model 612E	Natural gas fired, stationary.

hotsy
CLEANING SYSTEMS®

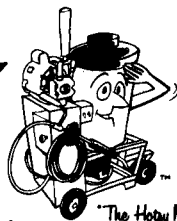

THE HOTSY CORPORATION
21 Inverness Way East, Englewood, Colorado 80112
(303) 770-5200 • TWX 910/935-0792
Toll Free: 1 (800) 525-9837



DAVIDSON
CONSTRUCTION MATERIALS, INC.
P.O. BOX 6267, BEAUMONT, TEXAS 77705
713 - 722-4321

Davidson
CONSTRUCTION MATERIALS
Inc.
P. O. BOX 6267
BEAUMONT, TEXAS 77705



VOL 008 PAGE 56

NO. _____ TIME: 10:20 AM

APR 14 1983

TYLER COUNTY
CLERKS OFFICE
WOODVILLE, TX 75979

SEALED BID
OPEN APRIL 15

GRACE BOSTICK, COUNTY CLERK
TYLER COUNTY, TEXAS
BY: *Grace Bostick*

MANN Furniture CO.

206 BLUFF STREET PHONE BU 3-3740
WOODVILLE, TEXAS

April 15, 1983

Bid approved

VOL 008 PAGE 57

Tyler County Courthouse
Probation Office
Woodville, Tx: 75979

Re: Whirlpool Air Conditioner
High Efficiency Unit
7.5 EER 12,500 BTU
Whirlpool

TO WHOM IT MAY CONCERN:

We submit a bid of \$429.00 installed with normal installation (no extra carpenter lumber or electrical material or labor considered). This price includes our labor required to do the job. Warranty includes free 5 years on compressor and 1 year on all other parts and labor.

Thank you for your consideration.

David Mann
Yours very truly,

David Mann
Mann Furniture

DPM:d

MANN FURNITURE COMPANY

206 W. BLUFF STREET

WOODVILLE, TEXAS 75979

VOL 008 PAGE 58

NO. _____ TIME: 9:35 AM

Air Conditioner Bid

APR 15 1983

GRACE BOSTICK, COUNTY CLERK
TYLER COUNTY, TEXAS

BY: *Jean Phillips*
JEAN PHILLIPS

Tyler County Courthouse
Probation Dept. Office

Woodville, Tx. 75979

MCCLURE FURNITURE COMPANY

305 N. MAGNOLIA
WOODVILLE, TEXAS 75979

VOL 008 PAGE 59

TO

DATE April 12, 1983

SUBJECT

My estimate on a Admiral 11,500 - 1 ton -- 6.9 - 7.0 EERS BTU 220V at 499.95.

Thomas McClure

Thomas McClure

McCLURE FURNITURE COMPANY

305 N. MAGNOLIA
WOODVILLE, TEXAS 75979

VOL 008 PAGE 60

NO. _____ TIME: 1:00 PM

bid for Air Conditioner

APR 12 1983

GRACE BOSTICK, COUNTY CLERK
TYLER COUNTY, TEXAS
BY: *Grace Bostick*

THE FURNITURE CENTER

107 EAST BLUFF • PHONE 283-2005 8101

WOODVILLE, TEXAS 75979

VOL 008 PAGE 61

I will furnish and install a 12,000 BTU
Gibson air conditioner with air sweep.

Sale price is \$489⁰⁰

Thank you for your
consideration -

Phil McClure

Friedrich

THE FURNITURE CENTER
107 EAST BLUFF
WOODVILLE, TEXAS 75979

VOL 008 PAGE 62

NO. _____ TIME: 8:15 ^{AM}/_{PM}

APR 15 1983

GRACE BOSTICK, COUNTY CLERK
TYLER COUNTY, TEXAS

Grace Bostick

Tyler County Courthouse

Air Conditioned Bid

DILL'S APPLIANCE & REFRIGERATION

Sales & Service
28 Years Experience

P. O. Box 716
WOODVILLE, TEXAS 75979
Phone 283-2714

JOB WORK ORDER

1843

DATE OF ORDER
4/11/83

CUSTOMER'S ORDER NO.	PHONE	MECHANIC	HELPER	STARTING DATE <i>1/1</i>
BILL TO <i>Tyler Co. Probation Dept</i>				ORDER TAKEN BY
ADDRESS <i>a/c Bid</i>				<input type="checkbox"/> DAY WORK <input type="checkbox"/> CONTRACT <input type="checkbox"/> EXTRA
CITY				
JOB NAME AND LOCATION VOL 008 PAGE 64				
DESCRIPTION OF WORK: <i>High d</i>				JOB PHONE

569.00
installation *35.00*

1 yr 100% warranty

5 yr. on seal system

	TOTAL MATERIALS	<i>569 00</i>
	TOTAL LABOR	<i>35 00</i>
	TAX	<i>28 45</i>
DATE COMPLETED <i>1/1</i>	WORK ORDERED BY	TOTAL AMOUNT \$

Signature _____

No one home
 Total amount due for above work: or
 Total billing to be mailed after completion of work

I hereby acknowledge the satisfactory completion of the above described work.

*News Appraisal
2018 So. Magnolia
Woodville*

WOODVILLE, TX
PM
APR 13
1983

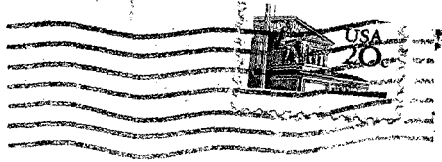

VOL 008 PAGE 65

Woodville 75779

H

NO. _____ TIME: 10:00 ^{AM} PM

APR 13 1983

GRACE BOSTICK, COUNTY CLERK
JUNIOR COUNTY, TEXAS

BY: *D. Langham*

VOL 008 PAGE 66